

### Configuration Data

Model **P14** **1** - **351SI**

### Electronic Metering Pumps

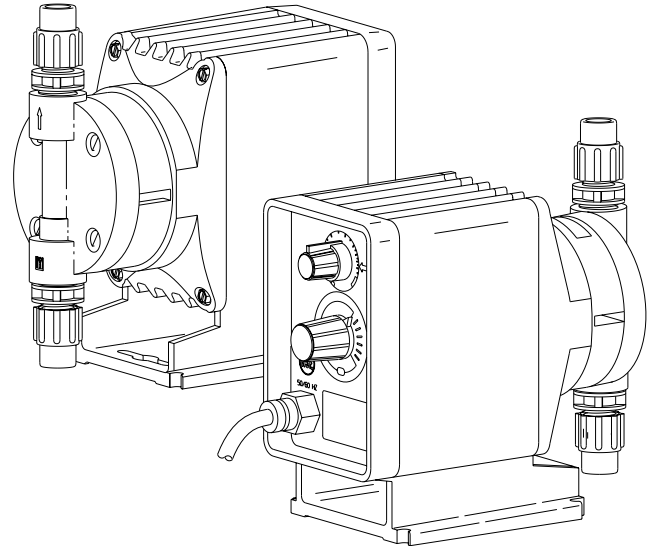

#### Manual Control

Speed (stroking frequency) fixed and stroke length manually adjustable.

- P02 --- 0.20 GPH (0.79 l/h) --- 150 psi (10.3 Bar)
- P03 --- 0.40 GPH (1.6 l/h) --- 110 psi (7.6 Bar)
- P04 --- 0.58 GPH (2.2 l/h) --- 250 psi (17.3 Bar)
- P05 --- 1.00 GPH (3.8 l/h) --- 110 psi (7.6 Bar)
- P06 --- 2.00 GPH (7.6 l/h) --- 50 psi (3.5 Bar)

#### Dual Manual Control

Speed (stroking frequency) and stroke length manually adjustable.

- P12 --- 0.20 GPH (0.79 l/h) --- 150 psi (10.3 Bar)
- P13 --- 0.42 GPH (1.6 l/h) --- 110 psi (7.6 Bar)
- P14 --- 0.58 GPH (2.2 l/h) --- 250 psi (17.3 Bar)
- P15 --- 1.00 GPH (3.8 l/h) --- 110 psi (7.6 Bar)
- P16 --- 2.00 GPH (7.6 l/h) --- 50 psi (3.5 Bar)

#### Voltage Code

- 1 ----- 120 VAC US Plug
- 2 ----- 240 VAC US Plug
- 3 ----- 220-240 VAC DIN Plug
- 5 ----- 240-250 VAC, UK Plug
- 6 ----- 240-250 VAC, Aust./NZ Plug
- 7 ----- 220 VAC, Swiss Plug

#### Liquid End

See next page for complete liquid end specifications and selection.



### Specifications

Series	Strokes Per Minute (Adjustable)		Stroke Length (Adjustable) Recommended Minimum	Average Input Power @ Max Speed	Shipping Weight
	Min	Max			
P02, P03	fixed - 60		30%	22 watts	7.6 lbs (3.5 kg)
P04	fixed - 100		20%		
P05	fixed - 100		20%		
P06	fixed - 100		20%		
P12, P13	.6	60	30%		
P14	1	100	20%		
P15	1	100	20%		
P16	1	100	20%		

### Dimensions

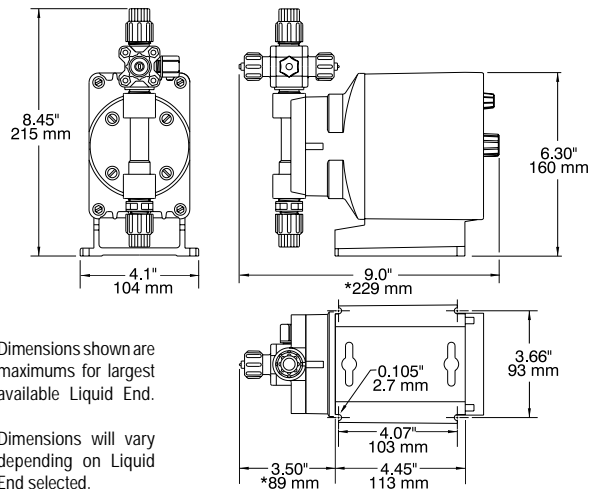

**8 Post Office Square**  
**Acton, MA 01720 USA**  
**TEL: (978) 263-9800**  
**FAX: (978) 264-9172**  
<http://www.lmipumps.com>



# Configuration Data & Materials of Construction

Drive Assembly	Liquid End No.	Size Code	Materials of Construction				Accessory	Tubing & Connections	
			Head & Fittings	Balls	Liquifram™	Check Valve		Discharge	Suction
P02	350SI†	0.5	Acrylic / PGC™	Ceramic	Fluorofilm™	PGC™ / Polyprel®	4FV	PE .250" O.D.	
	351SI†	0.5	PGC™ / PGC™	Ceramic	Fluorofilm™	PGC™ / Polyprel®	4FV	PE .250" O.D.	
P04	352SI†	0.5	PVDF / PVDF	Ceramic	Fluorofilm™	PVDF / Polyprel®	4FV	PE .250" O.D.	
P12	353SI†	0.5	PVDF / PVDF	Ceramic	Fluorofilm™	PVDF / PTFE	4FV	PE .250" O.D.	
P14	156	0.5	Acrylic / PP	316 S.S.	Fluorofilm™	Hypalon®		PE .5" O.D. Vinyl .938" O.D.	
	257	0.5	316 S.S.	316 S.S.	Fluorofilm™	316 S.S.		Pipe 1/4" NPT M	
P03	390SI†	0.9	Acrylic / PGC™	Ceramic	Fluorofilm™	PGC™ / Polyprel®	4FV	PE .375" O.D.	
	391SI†	0.9	PGC™ / PGC™	Ceramic	Fluorofilm™	PGC™ / Polyprel®	4FV	PE .375" O.D.	
P05	392SI†	0.9	PVDF / PVDF	Ceramic	Fluorofilm™	PVDF / Polyprel®	4FV	PE .375" O.D.	
P13	393SI†	0.9	PVDF / PVDF	Ceramic	Fluorofilm™	PVDF / PTFE	4FV	PE .375" O.D.	
P15	297	0.9	316 S.S.	316 S.S.	Fluorofilm™	316 S.S.		Pipe 1/4" NPT M	
	86	0.9	Acrylic / PP	316 S.S.	Fluorofilm™	Hypalon®		PE .5" O.D. Vinyl .938" O.D.	
P06	360SI†	1.8	Acrylic / PGC™	Ceramic	Fluorofilm™	PGC™ / Polyprel®	4FV	PE .375" O.D.	
	361SI†	1.8	PGC™ / PGC™	Ceramic	Fluorofilm™	PGC™ / Polyprel®	4FV	PE .375" O.D.	
P16	362SI†	1.8	PVDF / PVDF	Ceramic	Fluorofilm™	PVDF / Polyprel®	4FV	PE .375" O.D.	
	363SI†	1.8	PVDF / PVDF	Ceramic	Fluorofilm™	PVDF / PTFE	4FV	PE .375" O.D.	
	277	1.8	316 S.S.	316 S.S.	Fluorofilm™	316 S.S.		Pipe 1/4" NPT M	
	76	1.8	Acrylic / PP	316 S.S.	Fluorofilm™	Hypalon®		PE .5" O.D. Vinyl .938" O.D.	

See front page for voltage code specifications.

**3FV** indicates that the pump is equipped with an LMI Three Function Valve (pressure relief, priming aid, line drain).

Fluorofilm™ is a copolymer of PTFE and PFA. Polyprel® is an elastomeric PTFE copolymer.

† To specify 1/4" NPT male, change 'I' to 'P'. To specify black, UV resistant tubing, change 'I' to 'U'. To specify Bleed 4FV, change 'S' to 'B'. To specify 3FV, change 'S' to 'T'.

**4FV** indicates that the pump is equipped with an LMI Four Function Valve. This diaphragm type, anti-syphon/pressure relief valve is installed on the pump head. It provides anti-syphon protection and aids in priming, even under pressure.

Polyprel is a registered trademark of Liquid Metronics, Inc. Fluorofilm, Liquifram, PGC are trademarks of Liquid Metronics, Inc. Hypalon is a registered trademark of E. I. du Pont de Nemours & Co., Inc.

# Output Information

Series	Gallons per Hour		Liters per Hour		mL/cc per Minute		mL/cc per Stroke		Maximum Injection Pressure	
	Min	Max	Min	Max	Min	Max	Min	Max		
P02	0.063	0.21	0.237	0.79	3.94	13	0.07	0.22	150 psi	(10.3 Bar)
P03	0.125	0.42	0.473	1.6	7.89	26	0.13	0.44	110 psi	(7.6 Bar)
P04	0.117	0.58	0.442	2.2	7.36	37	0.07	0.37	250 psi	(17.3 Bar)
P05	0.200	1.0	0.757	3.8	12.62	63	0.13	0.63	110 psi	(7.6 Bar)
P06	0.400	2.0	1.510	7.6	25.23	126	0.25	1.26	50 psi	(3.5 Bar)
P12	0.001	0.21	0.002	0.79	0.04	13	0.07	0.22	150 psi	(10.3 Bar)
P13	0.001	0.42	0.005	1.6	0.08	27	0.13	0.44	110 psi	(7.6 Bar)
P14	0.001	0.58	0.004	2.2	0.07	37	0.07	0.37	250 psi	(17.3 Bar)
P15	0.002	1.0	0.008	3.8	0.13	63	0.13	0.63	110 psi	(7.6 Bar)
P16	0.004	2.0	0.015	7.6	0.25	126	0.25	1.26	50 psi	(3.5 Bar)