

Specification Sheet

Series B

GENERAL

Chemical metering pumps shall be positive displacement, Liquifram™ type pumps that are UL and CUL approved. Output volume shall be adjustable while pumps are in operation from zero to maximum capacity of:

- B11, B71, B91 - 1.6 GPH (6.1 liters per hour)
- B12, B72, B92 - 2.5 GPH (9.5 liters per hour)
- B13, B73, B93 - 4.5 GPH (17.0 liters per hour)
- B14, B74, B94 - 7.0 GPH (26.5 liters per hour)

Chemical metering pumps shall be capable, without a hydraulically backed diaphragm, of injecting solutions against pressures up to:

- B11, B71, B91 - 150 psig(10.3 bar)
- B12, B72, B92 - 100 psig(6.9 bar)
- B13, B73, B93 - 50 psig(3.4 bar)
- B14, B74, B94 - 30 psig(2.1 bar)

SERIES B1

Adjustment shall be by means of readily accessible dial knobs, one for changing stroke length and the other for changing stroke frequency. Both knobs are to be located opposite the liquid handling end.

SERIES B7

Control of Series B7 metering pumps shall be selectable between internal and external pulsing by means of a 3-position center-off switch. Stroke length shall be adjustable by means of readily accessible dial knob. When in external pulsed mode, Series B7 units shall accept signals without the use of electrical timer or internal timer. Pressure capacity shall be adjustable to reduce noise, vibration and wear.

SERIES B9

Series B9 metering pumps shall have a clear liquid crystal display. Control shall be selectable between internal and external pulsing by means of a tactile keypad. Internal stroke frequency shall be adjustable from 1 stroke per hour to 100 strokes per minute. Pressure capacity

shall be keypad adjustable to reduce noise, vibration and wear. Metering pump shall be capable of dividing or multiplying pulse inputs from 1 to 999 or responding directly or inversely to a 4-20mA input signal.

DRIVE

The pump drive shall be totally enclosed with no exposed moving parts. Solid state electronic pulser shall be fully encapsulated and supplied with quick connect terminals at least 3/16" (4.75 mm) wide. Electronics shall be housed in chemical resistant enclosure at the rear of the pump for maximum protection against chemical spillage. Electrical power consumption shall not exceed 29 watts per hour under full speed and maximum pressure conditions. Pump weight shall not exceed 15 lbs (6.9 kg).

AUTOMATIC PRESSURE RELIEF

To eliminate need for pressure relief valve, Liquifram™ shall automatically stop pulsating when discharge pressure exceeds pump pressure rating by not more than 35%.

MATERIAL

Chemical metering pump housing shall be of chemically resistant glass fiber reinforced thermoplastic. All exposed fasteners shall be stainless steel. Chemical metering pump valves shall be ball type, with ceramic balls¹. Valve seat and seal ring shall be renewable by replacing the combination seat-seal ring² or cartridge valve assembly. Pump head shall be of transparent acrylic³ material capable of resisting the pumped chemical. Fittings and connections at pump head shall be PVC⁴.

CHECK VALVES AND TUBING

A total of 16 ft (4.8 m) of polyethylene tubing⁵ shall be provided per pump complete with compression connections. A foot valve with integral one piece strainer shall be provided for the suction line, and an injection/back pressure check valve with 1/2" NPT male connection for the injection point. The injection check valve shall incorporate a dilating orifice which prohibits scale formation and accumulation of crystalline deposits.

Notes:

1. Type 316 stainless steel or PTFE may be specified.
2. Hypalon®, PTFE or Polyprel® may be specified.
3. PVDF, PVC, Polypropylene, or Type 316 stainless steel may be specified.
4. PVDF, Polypropylene, or Type 316 stainless steel may be specified.
5. 6 ft (1.8 m) of vinyl suction tubing may be specified in place of polyethylene for the suction side only. 1/4" or 1/2" pipe thread may be specified.



8 Post Office Square
Acton, MA 01720 USA
TEL: (978) 263-9800
FAX: (978) 264-9172
<http://www.lmipumps.com>



B Series

LE Codes	W	X	Y	Z
71T, 72T, 75T, 81T, 82T, 85T	3.25 (82.5mm)	8.5 (216.0mm)	.65 (16.5mm)	10.70 (271.8mm)
71S, 72S, 75S 81S, 82S, 85S	4.55(115.6mm)	9.7 (246.5mm)	.65 (16.5mm)	12.00 (304.8mm)
74, 94	3.25 (82.5mm)	8.5 (216.0mm)	.65 (16.5mm)	10.70 (271.8mm)
76, 86	3.55 (90.2mm)	9.5 (241.3mm)	.65 (16.5mm)	11.00 (279.4mm)
77, 97	3.25 (82.5mm)	8.5 (216.0mm)	.65 (16.5mm)	10.70 (271.8mm)
91T, 92T, 95T	3.25 (82.5mm)	8.5 (216.0mm)	.65 (16.5mm)	10.70 (271.8mm)
91S, 91FS 92S, 95S	4.55(115.6mm)	9.7 (246.5mm)	.65 (16.5mm)	12.00 (304.8mm)

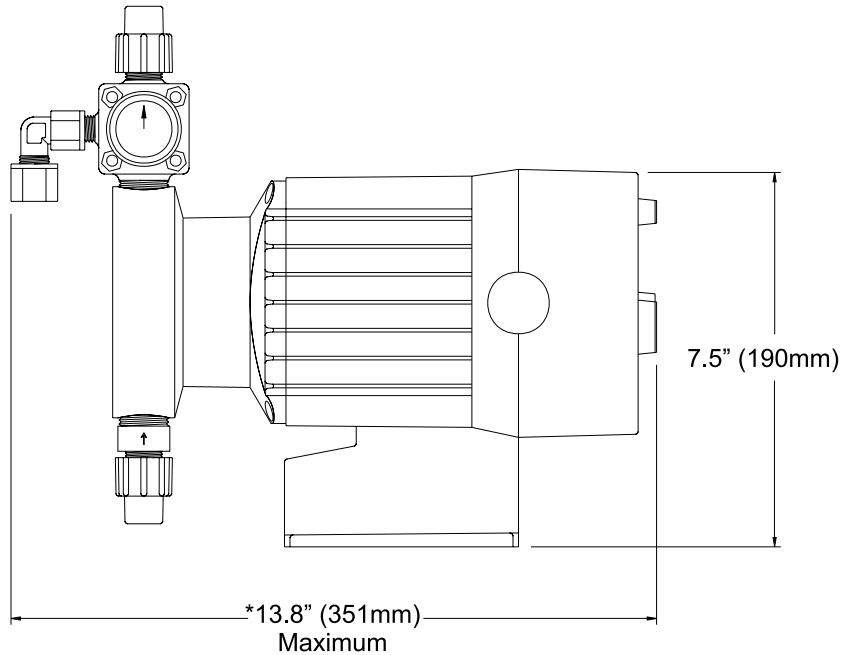
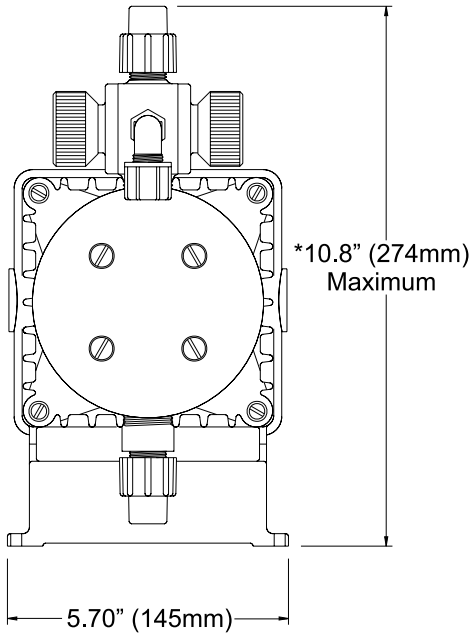

*Dimensions shown are maximum for largest liquid end available. These dimensions vary depending on the liquid end selected.

